

No.	DESCRIPTION	MATERIAL
1	BODY	CAST LOW LEAD BRASS ALLOY
2	KEY	CAST LOW LEAD BRASS ALLOY
3	KEY WASHER	CAST BRASS ASTM B62 ALLOY C83600
4	KEY NUT	CAST BRASS ASTM B62 ALLOY C83600
5	COPPER TUBE NUT	CAST BRASS ASTM B62 ALLOY C83600

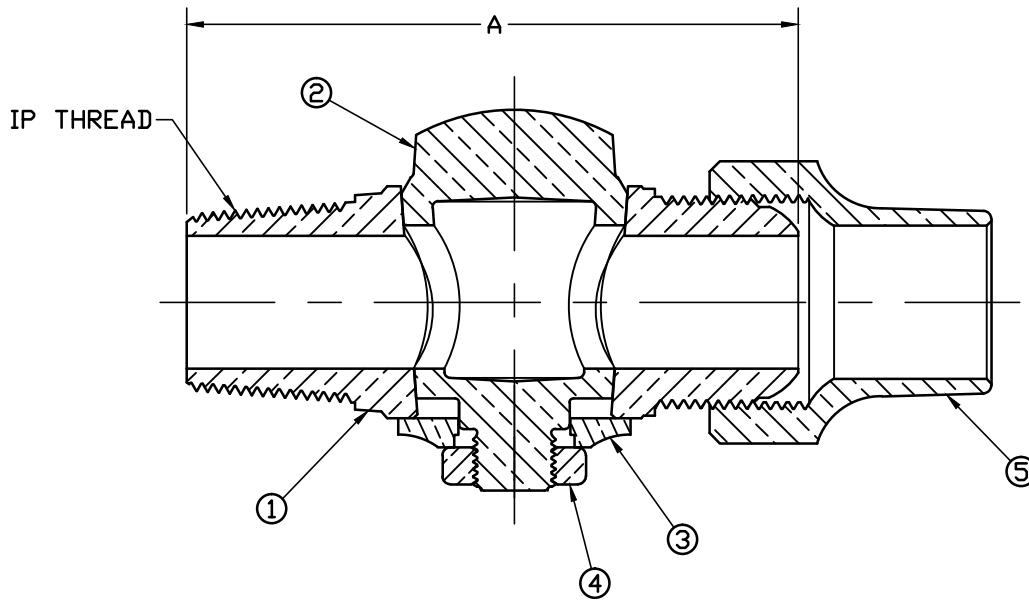

SIZE	A
3/4	3-27/32"
1	4-39/64"

FILEPATH: PRODD-ENG\JJ\SUBMITTALS\E1505

PART NUMBER  
E1505  
JJ-MRKTG

						DRFTR	RWB	2/26/10	<b>JAMES JONES CO.</b>	
						CHKR				
						ENGR				
						MGR			UNLESS OTHERWISE NOTED THIRD ANGLE PROJECTION	
									SURFACE PREPARATION:	
									BREAK CORNER(S) ---- .000	
									SURFACE FINISH -- 000 RMS	
									TOLERANCE(S):	
									LINEAR ----- ± .000	
									ANGULAR ----- ± 0°00'	
									REF. No.	SCALE
										FULL
									STK No:	
									MAT'L:	
									DESCR. GROUND KEY LLB CORPORATION VALVE	
									PART NUMBER	
									E1505	
REV	ECR	DESCRIPTION	DATE	BY	CHKR					