

No.	DESCRIPTION	MATERIAL
1	BODY	CAST LOW LEAD BRASS ALLOY
2	KEY	CAST LOW LEAD BRASS ALLOY
3	KEY WASHER	CAST BRONZE ASTM B62 ALLOY C83600
4	KEY NUT	CAST BRONZE ASTM B62 ALLOY C83600

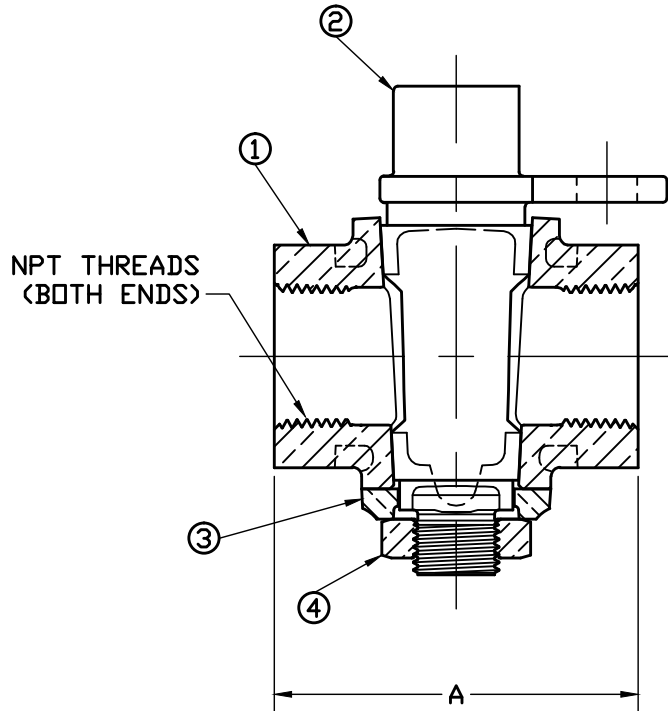

SIZE	A	NPT SIZE
3/4	2.64	3/4"
1	3.25	1"

PART NUMBER
E182
JJ-MRKTG

FILEPATH: PROD-ENG\JJ\SUBMITTALS\E182

						DRFTR JGarvin 3/5/10	JAMES JONES CO.			
						CHKR				
						ENGR				
						MGR				
						BY	DATE	UNLESS OTHERWISE NOTED	THIRD ANGLE PROJECTION	
						STK No:		SURFACE PREPARATION:		
						MAT'L:		BREAK CORNER(S) ---- .000		
						DESCR.		SURFACE FINISH -- XX RMS	REF. No.	SCALE
								TOLERANCE(S):		FULL
								LINEAR ----- ± .000		
								ANGULAR ----- ± 0°00'		
REV	ECR	DESCRIPTION	DATE	BY	CHKR	GROUND KEY VALVE LOW LEAD BRASS(FIP x FIP)				PART NUMBER E182