

No.	DESCRIPTION	MATERIAL
1	STEM	CAST LOW LEAD BRASS ALLOY
2	O-RING	EPDM D2000
3	BALL	CAST LOW LEAD BRASS ALLOY
4	GASKET - SEAL	NITRILE D2000
5	BODY	CAST LOW LEAD BRASS ALLOY
6	O-RING	EPDM D2000
7	END PIECE	CAST LOW LEAD BRASS ALLOY
8	TUBE NUT	CAST BRASS ASTM B62 ALLOY C83600

SIZE	ØA	B	C	D	E
3/4	.75	3.95	.84	1.36	2.20
1	1.00	4.87	1.15	1.59	2.74
1-1/2	1.50	6.11	1.66	2.40	4.06
2	2.00	7.21	2.00	2.72	4.72

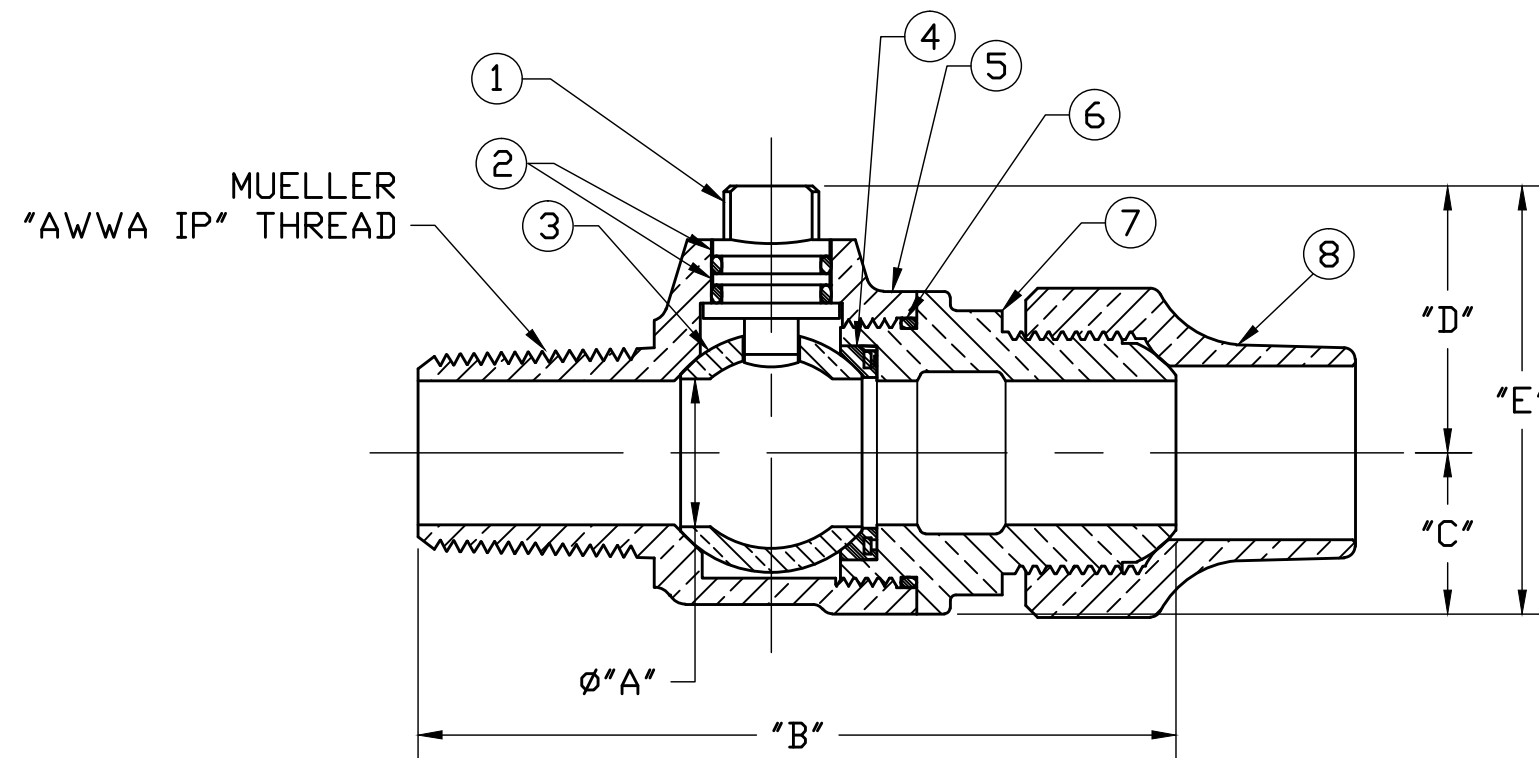

FILEPATH: PROD-ENG\JJ\SUBMITTALS\E1929

						DRFTR	RWB	11/12/09	JAMES JONES CO.	
						CHKR				
						ENGR			UNLESS OTHERWISE NOTED THIRD ANGLE PROJECTION 	
						MGR				
									REF. No.	SCALE
										NONE
									SURFACE PREPARATION: BREAK CORNER(S) ---- .000 SURFACE FINISH -- 000 RMS TOLERANCE(S): LINEAR ----- ± .000 ANGULAR ----- ± 0°00'	
									BY _____ DATE _____ STK No: _____ MAT'L: _____	
									DESCR. MUELLER CORPORATION BALL VALVE ("AWWA IP" x CS)	
									PART NUMBER E1929	
									PER EST NO: DXXXX EST FIN WT = 0.0000 lbs	

PART NUMBER
E1929
JJ-MRKTNG