

No.	DESCRIPTION	MATERIAL
1	STEM	CAST LOW LEAD BRASS ALLOY
2	O-RING	EPDM ASTM D2000
3	BALL	CAST LOW LEAD BRASS ALLOY
4	GASKET-SEAL	NITRILE ASTM D2000
5	BODY	CAST LOW LEAD BRASS ALLOY
6	CAP	CAST BRASS ASTM B62 ALLOY C83600
7	SOLID PIN	AISI 304 ANNEALED STAINLESS STEEL
8	O-RING	EPDM ASTM D2000
9	SEALING PLUG	CAST LOW LEAD BRASS ALLOY
10	SPUD	CAST LOW LEAD BRASS ALLOY
11	TUBE NUT	CAST BRASS ASTM B62 ALLOY C83600

SIZE	ØA	B	C	D
1-1/2"	1.50	1.81	5.36	3.36
2"	2.00	2.19	6.29	4.06

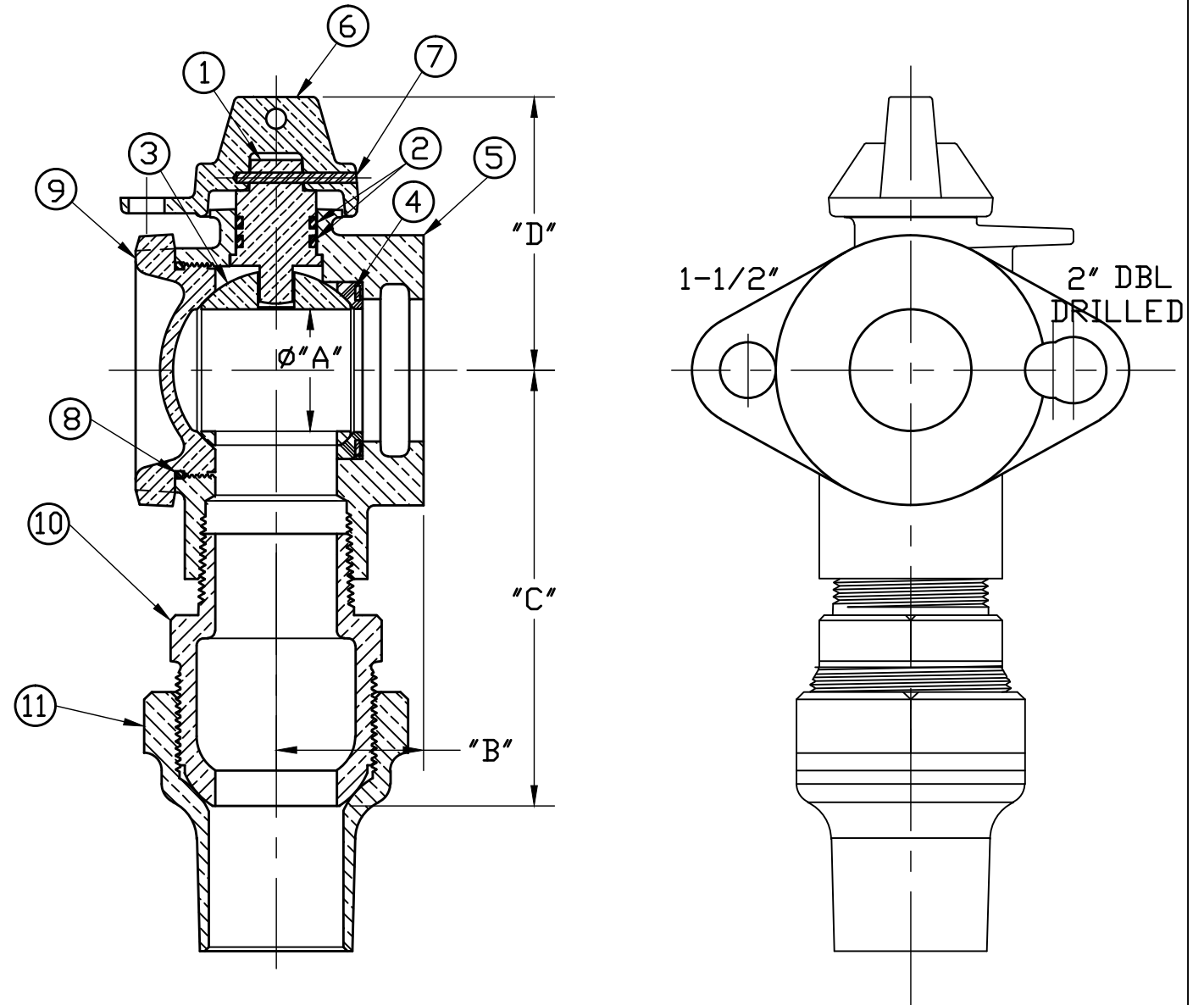

FILEPATH: PROD-ENG\JJ\SUBMITTALS\E1973W

						DRFTR	RWB	11/12/09	<b>JAMES JONES CO.</b> UNLESS OTHERWISE NOTED SURFACE PREPARATION: BREAK CORNER(S) ---- .000 SURFACE FINISH -- XX RMS TOLERANCE(S): LINEAR ----- ± .000 ANGULAR ----- ± 0°00'		THIRD ANGLE PROJECTION	
						CHKR						
						ENGR						
						MGR					BY    DATE	
						STK No:			PART NUMBER <b>E1973W</b>			
						MAT'L:						
						DESCR.			BALL ANGLE METER VALVE 2 PC CONSTR ("CS" x METER)			
REV	ECR	DESCRIPTION	DATE	BY	CHKR	PER EST NO: DXXXX EST FIN WT = 0.0000 lbs						

PART NUMBER  
**E1973W**  
 JJ-MRKTG