

No.	DESCRIPTION	MATERIAL
1	SPUD	CAST LOW LEAD BRASS ALLOY
2	CONN. NUT	CAST BRASS ASTM B62 ALLOY C83600
3	CTS GSKT SUB	SBR ASTM D2000 - GSKT 410 _{ss} - BAND

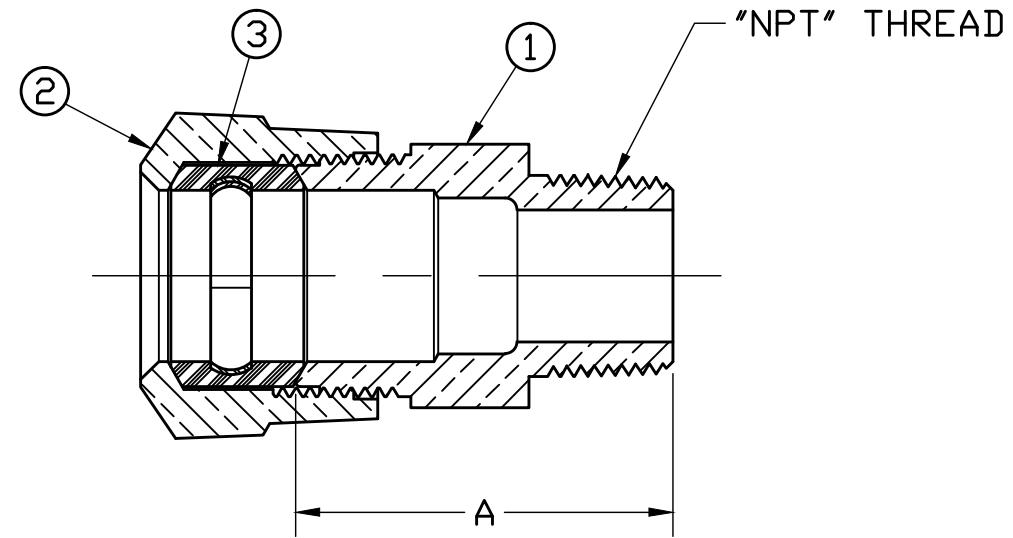

SIZE	A	NPT SIZE
3/4	1-31/32"	3/4"
1x3/4	1-63/64"	3/4"
1	2-5/32"	1"
1-1/4	2-5/16"	1-1/4"
1-1/2	2-3/8"	1-1/2"
2	2-5/8"	2"

FILEPATH: PROD-ENG\JJ\SUBMITTALS\E2605SG

						DRFTR	RWB	6/9/08	JAMES JONES CO.		
						CHKR					
						ENGR					
						MGR					
									UNLESS OTHERWISE NOTED	THIRD ANGLE PROJECTION	
									SURFACE PREPARATION:		
									BREAK CORNER(S) ----- .000		
									SURFACE FINISH -- XX RMS	REF. No.	SCALE
									TOLERANCE(S):		
									LINEAR ----- ± .000		
									ANGULAR ----- ± 0°00'		
									STK No:		
									MAT'L:		
									DESCR.	STRAIGHT COUPLING SERVICE FITTING (110 CTS x MIP)	
REV	ECR	DESCRIPTION	DATE	BY	CHKR					PART NUMBER	E2605SG

PART NUMBER
E2605SG
 JJ-MRKTG