

No.	DESCRIPTION	MATERIAL
1	BODY	CAST LOW LEAD BRASS ALLOY
2	CONN. NUT	CAST BRASS ASTM B62 ALLOY C83600
3	GASKET SUB.	SBR, D2000 - GSKT, 410ss - BAND

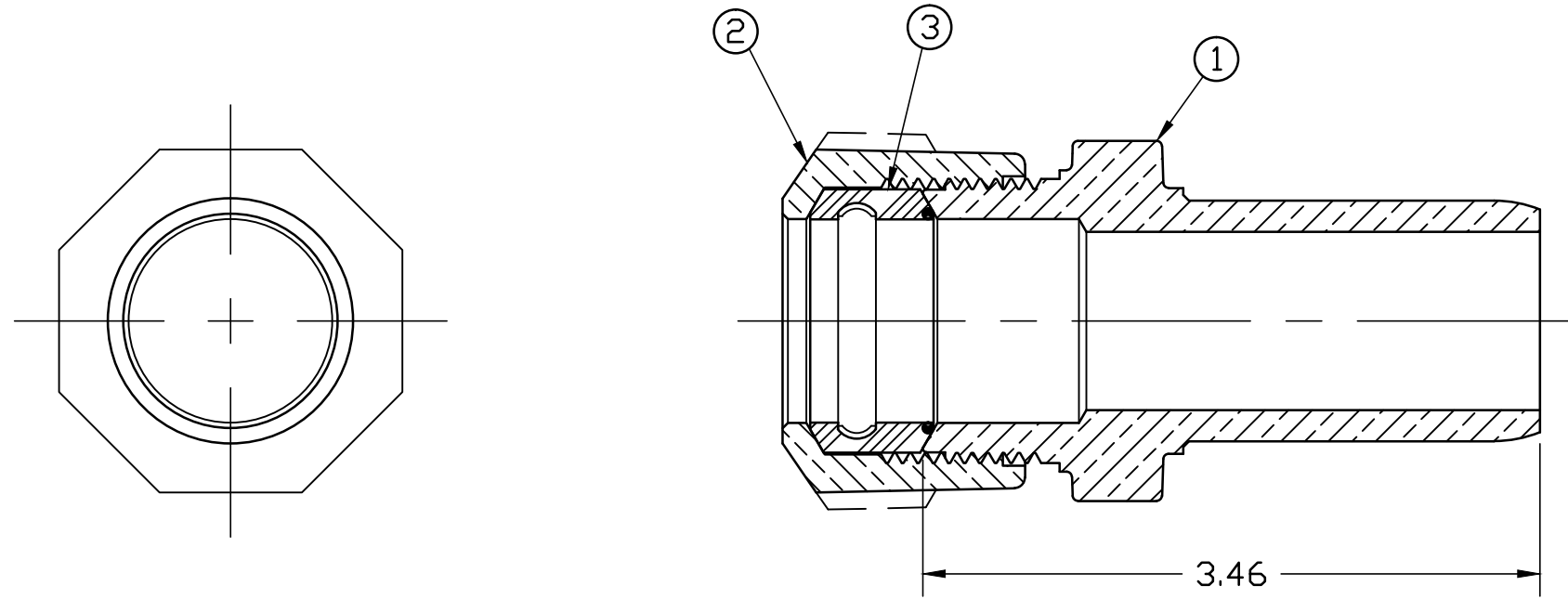

FILEPATH: PROD-ENG\JJ\SUBMITTALS\E2639SG

						DRFTR	RWB	2/5/10	JAMES JONES CO.	
						CHKR				
						ENGR				
						MGR				
									UNLESS OTHERWISE NOTED	THIRD ANGLE PROJECTION
									SURFACE PREPARATION:	
									BREAK CORNER(S) ---- .000	REF. No.
									SURFACE FINISH -- XX RMS	
									TOLERANCE(S):	
									LINEAR ----- ± .000	
									ANGULAR ----- ± 0°00'	
									STK No:	
									MAT'L:	
									DESCR.	
									1" CONVERSION COUPLING LLB	PART NUMBER
									PJ CTS x IPS TUBE	E2639SG
REV	ECR	DESCRIPTION	DATE	BY	CHKR					

PART NUMBER
E2639SG
JJ-MRKTG