

No.	QTY.	DESCRIPTION	MATERIAL
1	1	TAILPIECE	CAST BRASS ASTM B62 ALLOY C83600
2	1	COUPLING NUT	CAST BRASS ASTM B62 ALLOY C83600
3	1	RUBBER GASKET	NITRILE ASTM D2000

METER COUP. SIZE	"A"	NPT SIZE
3/4	TO BE SPECIFIED	3/4
1		1

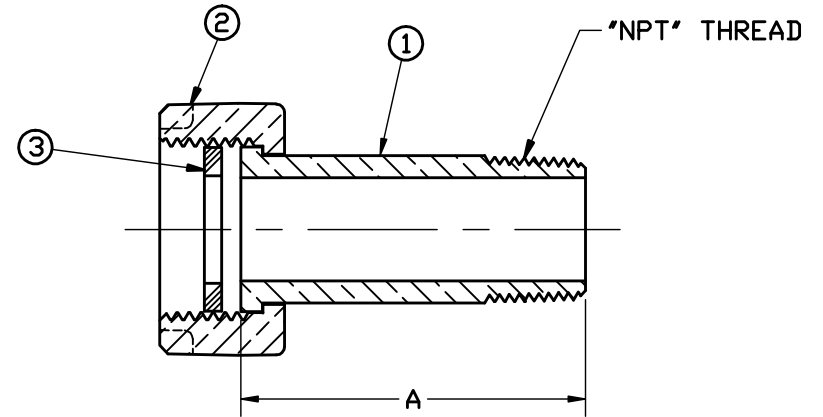

FILEPATH: PROD-ENG\JJ\SUBMITTAL\J130

						DRFTR JGarvir 1/8/07	JAMES JONES CO.			
									UNLESS OTHERWISE NOTED	THIRD ANGLE PROJECTION
									SURFACE PREPARATION: BREAK CORNER(S) ---- .000	REF. No. SCALE
									SURFACE FINISH -- XX RMS	
						BY DATE	TOLERANCE(S): LINEAR ----- ± .000	ANGULAR ----- ± 0°00'		
						STK No:				
						MAT'L:				
						DESCR.	METER COUPLING (METER SWIVEL NUT × MIP)			
REV	ECR	DESCRIPTION	DATE	BY	CHKR			PART NUMBER J130		

PART NUMBER
J130
JJ-MRKTG