

SECTION B-B

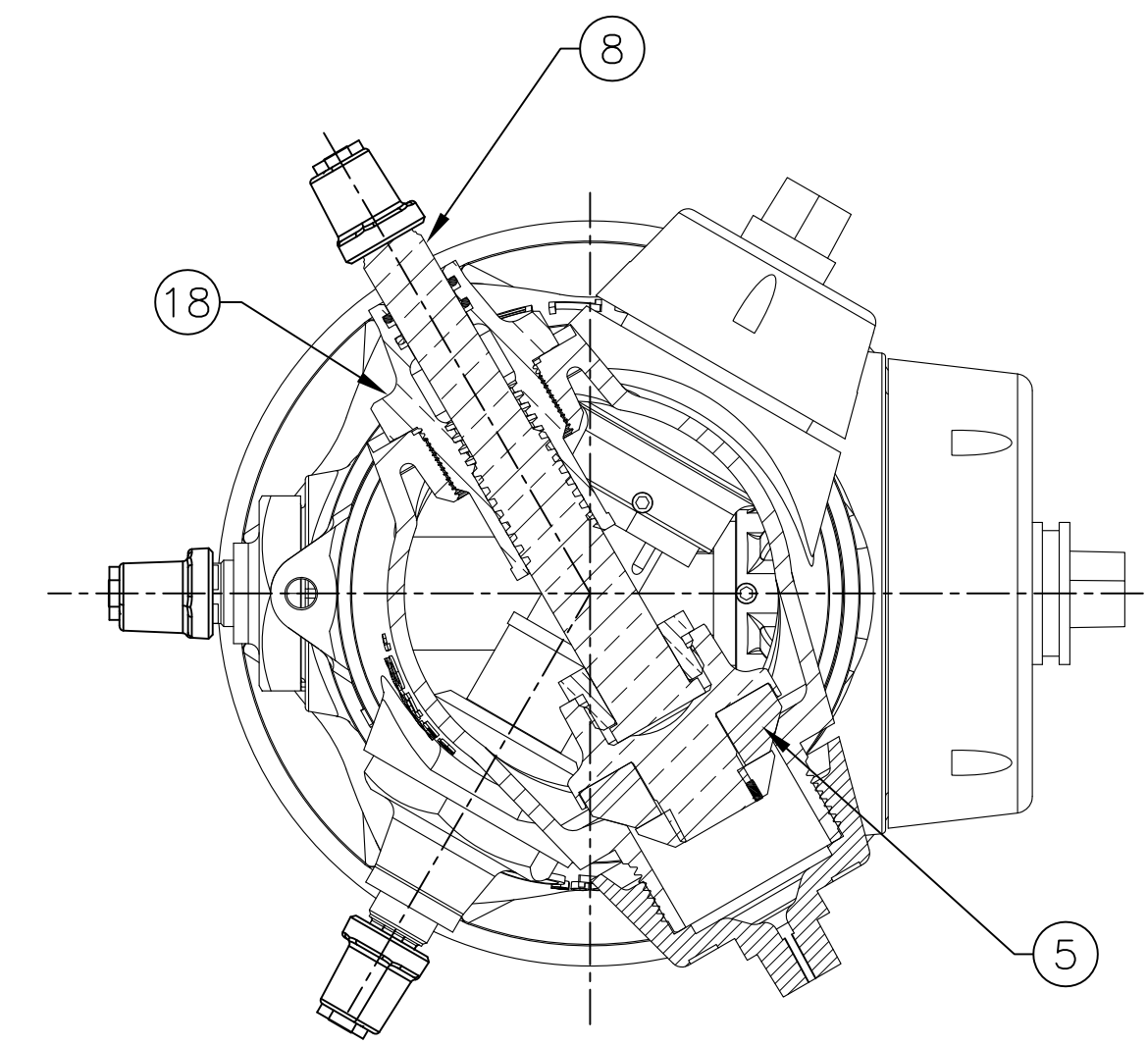

SECTION A-A

ITEM	QTY	PART No.	DESCRIPTION
1	1	34-0048	HYDRANT SPOOL
2	1	23-0075	CAP 4-1/2" TAPERED PLASTIC
3	2	23-0079	CAP 2-1/2" TAPERED PLASTIC
4	1	27-0501	DISC HOLDER ASSEMBLY 4-1/2"
5	2	27-0500	DISC HOLDER ASSEMBLY 2-1/2"
6	3	16-0016	STEM LOCKNUT
7	1	26-0093	STEM
8	2	26-0095	STEM
9	1	30-0501	CHAIN/RING SUBASSEMBLY 4"
10	6	194572	O-RINGS
11	3	21-0004	OPERATING NUT - PENT 1-1/8"
12	3	16-0254D	STEM NUT PENT RETAINER
13	1	34-0059	INSERT-LONG
14	1	20-0022	BOLT
15	1	16-0245	NUT
16	1	34-0046	HYDRANT HEAD
17	1	15-0164	O-RING HYDRANT SPOOL SEAL
18	2	34-0057	INSERT-MEDIUM
19	3	20-0026	SET SCREW
20	2	30-0500	CHAIN/RING SUBASSEMBLY 2-1/2"

(MILLIMETER) INCH		TOLERANCES - MACHINING UNLESS OTHERWISE NOTED BREAK EDGES FINISH SURFACES MACH. .006/.016 125		THIRD ANGLE PROJECTION
INITIAL RELEASE DRFT'R CHK'R APP	ANC 1-27-16	FRACTIONS $\pm 1/64$	DECIMALS 2 PL $\pm .025$ 3 PL $\pm .010$	PURCH. REF. NO. SCALE STK. NO.
JONES		MAT'L DESCR. J3760 PL 1-1/8 BRONZE HYD 4.5"x(2) 2.5", 6H, .75, 9.38B.C		REVISION NUMBER 34-0630 SHEET 1 OF 1

34-0630

REV.	DESCRIPTION	REF.	DRFT'R	CHK'R	APP.	DATE