

DWG NUMBER
E2613

44-MRKTNG

No.	DESCRIPTION	MATERIAL
1	BRANCH	CAST LOW LEAD BRASS ALLOY
2	PJ GASKET	EPDM
3	PJ WASHER	POLYPROPYLENE
4	PJ CPLG NUT	CAST BRASS ASTM B62 ALLOY C83600

PJ SIZE	NPT SIZE	BRANCH BETWEEN CENTERS
1"	3/4"	6-1/2"
1"	3/4"	7-1/2"
1"	3/4"	13-1/2"

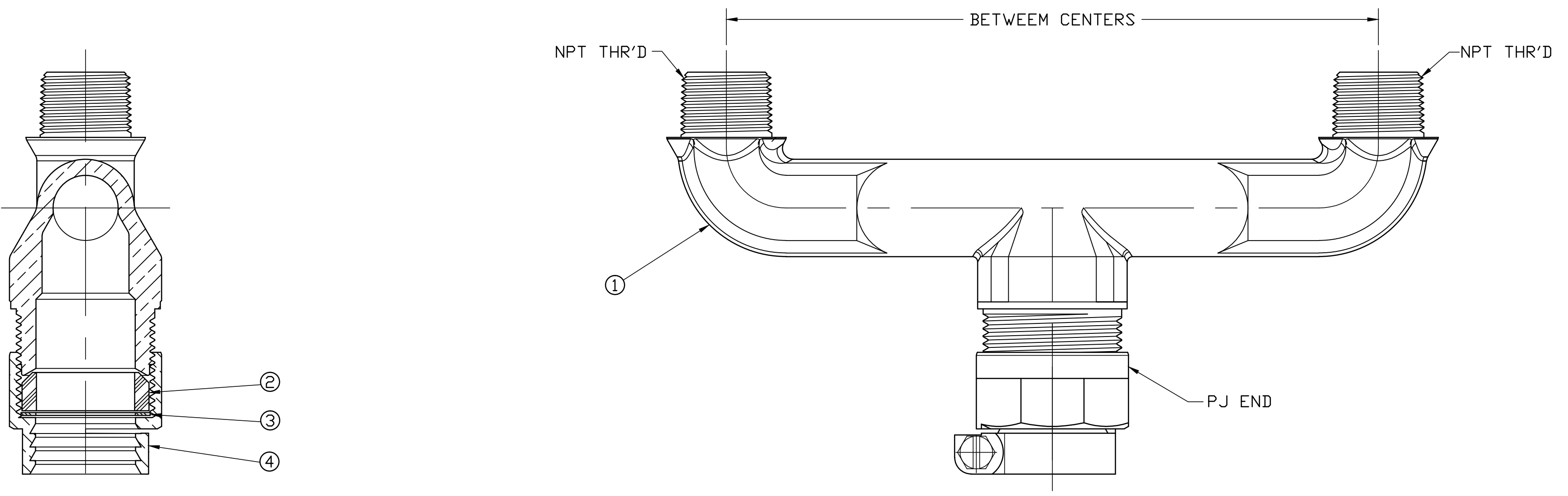

ALL WETTED PARTS ARE LOW LEAD BRASS ALLOY

FILEPATH: PRODD-ENG\JAMESJONES\ASYSUBMITTALS\E2613

DRFTR	RWB	6/30/16	JONES
CHKR			
ENGR			
MGR			
BY	DATE		UNLESS OTHERWISE NOTED
STK No:			SURFACE PREPARATION:
MAT'L:			BREAK CORNER(S) ---- .000
DESCR.	LLB U-BRANCH CONNX.		SURFACE FINISH -- XX RMS
PER EST NO: XXXXX	EST FIN WT = 0.0000 lbs		TOLERANCE(S):
			LINEAR ----- ± .000
			ANGULAR ----- ± 0°00'
			THIRD ANGLE PROJECTION
			REF. No.
			SCALE
			NONE
			DWG NUMBER
			E2613

TITLE TO AND OWNERSHIP OF THIS ENGINEERING DATA REMAINS IN Mueller Co. NO USE IS TO BE MADE OF THIS DATA EXCEPT AS SPECIFICALLY AUTHORIZED BY Mueller Co. ASSENT ON THE PART OF THE RECIPIENT TO THESE CONDITIONS IS PRESUMED