

J-5000 SHORT BREAK CHECK VALVE Installation Instructions

INSTALLATION

NOTE: The break check valve and wet barrel hydrant must be installed and maintained according to AWWA M17, C503, C600, and applicable local codes.

- A** Upon receipt of shipment, inspect break check valve assembly to ensure no damage or breakage occurred during shipment. All external bolts should be checked for tightness.
- B** Connect break check valve inlet to bury section and plumb.
- C** Attach hydrant to break check valve outlet (adapter plate) using gasket and bolts (see table below). Torque bolts to approximately 120 ft-lb. If a change in orientation of the pumper outlet is required, loosen the Traffic Flange nuts, lift hydrant and rotate using caution not to damage or displace the adapter O-ring. Re-tighten Traffic Flange nuts to 70-90 ft-lb.
- D** Test hydrant with line pressure before backfilling. Remove the cap from the top hydrant outlet. Slightly open the top outlet valve and slowly open the service gate valve to restore water to the hydrant. When all air is evacuated from the hydrant, water will begin to come out of the top nozzle. Firmly seat top valve. Completely open gate valve and check for leaks at flanges and seals.

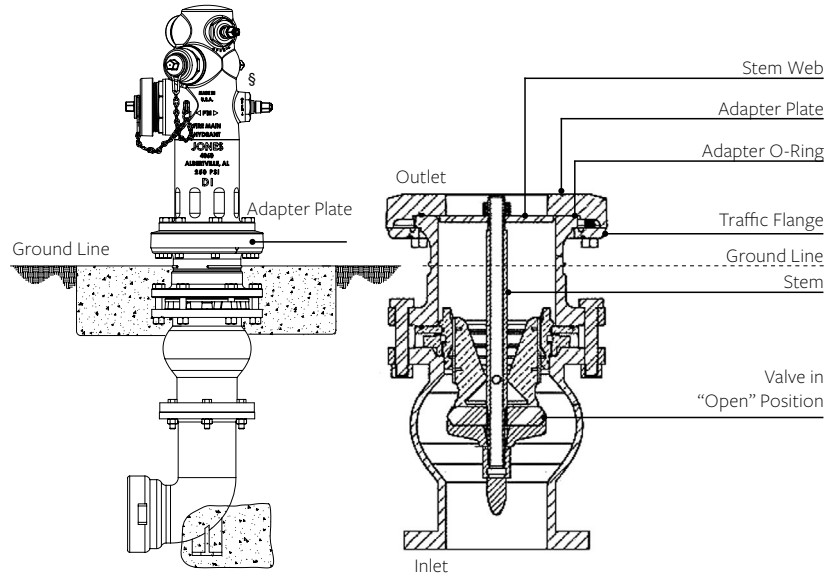

HYDRANT CAP SCREW KIT SELECTION

HYDRANT MATERIAL	NUMBER OF FLANGE HOLES	FLANGE BOLT SIZE	JONES CAP SCREW KIT PART #
Bronze	6	5/8" - 11 x 1 1/4"	20-0046
Iron	6	5/8" - 11 x 1 3/4"	20-0047
Iron	8	3/4" - 10 x 1 3/4"	20-0050
Bronze	8	3/4" - 10 x 1 1/4"	20-0051
Bronze	6 (SD Drill)	3/4" - 10 x 1 1/4"	20-0052
Iron	6 (SD Drill)	3/4" - 10 x 1 3/4"	20-0053

- E** Install concrete thrust collar at or near the ground line. Recommended collar dimensions are 8 inches thick and 30" x 30" square. These dimensions are dependent upon soil conditions.
- F** Flushing the hydrant is recommended following installation to remove any foreign material and ensure break check valve is set in the open position.

1470 S. Vintage Ave., Ontario, CA 91761, moreinfo@muellercompany.com, **P:** 800.423.1323

For more information about Jones® or to view our full line of water products, please visit joneswaterproducts.com or call Jones customer service at 1.800.423.1323.

Mueller refers to one or more of Mueller Water Products, Inc., a Delaware corporation ("MWP"), and its subsidiaries. MWP and each of its subsidiaries are legally separate and independent entities when providing products and services. MWP does not provide products or services to third parties. MWP and each of its subsidiaries are liable only for their own acts and omissions and not those of each other. MWP brands include Mueller®, Echologics®, Hydro Gate®, Hydro-Guard®, Jones®, Mi.Net®, Milliken®, Pratt®, Singer®, and U.S. Pipe Valve & Hydrant. Please see www.muellerwpp.com/about to learn more.

Copyright © 2018 James Jones Company, LLC. All Rights Reserved. The trademarks, logos and service marks displayed in this document are the property of Mueller Water Products, Inc., its affiliates or other third parties. Products above marked with a section symbol (§) are subject to patents or patent applications. For details, visit www.mwppat.com. These products are intended for use in potable water applications. Please contact your Mueller Sales or Customer Service Representative concerning any other application(s).

F 12717 10/18