

No.	DESCRIPTION	MATERIAL
1	SPUD	CAST LOW LEAD BRASS ALLOY
2	IPS PE GSKT	ASTM D2000(SBR)&410 STAINLESS STEEL
3	CONNX NUT	CAST BRASS ASTM B62 ALLOY C83600
4	CTS GSKT	ASTM D2000(SBR)&410 STAINLESS STEEL
5	CONNX NUT	CAST BRASS ASTM B62 ALLOY C83600

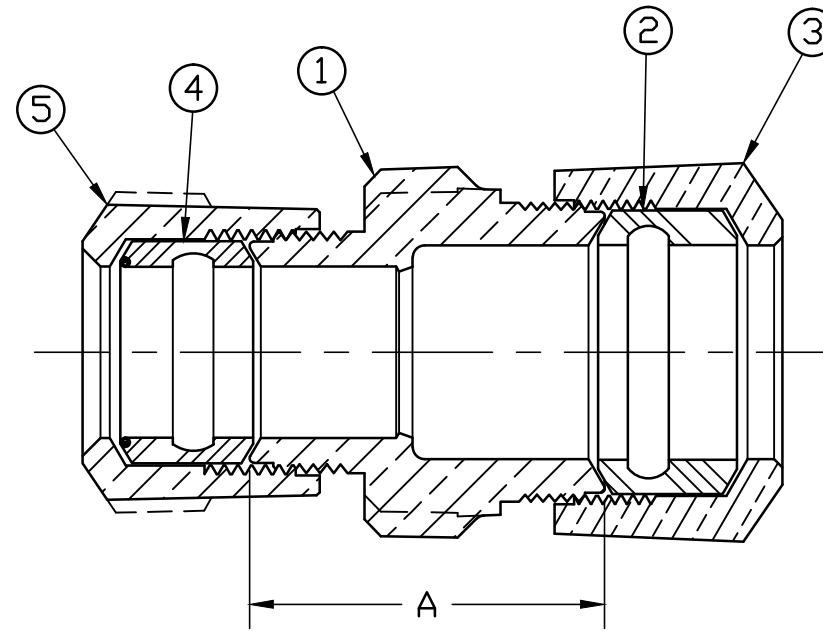

SIZE	A
3/4"	1.85
1"	2.15

ALL WETTED PARTS ARE LOW LEAD BRASS ALLOY

FILEPATH: PROD-ENG\JAMESJONES\ASYSUBMITTALS\E2612SGP

						DRFTR	RWB	4/22/16	JONES	UNLESS OTHERWISE NOTED THIRD ANGLE PROJECTION	REF. No.	SCALE NONE			
						CHKR									
						ENGR				SURFACE PREPARATION: BREAK CORNER(S) ---- .000 SURFACE FINISH -- XX RMS TOLERANCE(S): LINEAR ----- ± .000 ANGULAR ----- ± 0°00'					
						MGR									
							BY	DATE	STK No:						
									MAT'L:						
									DESCR.	STRAIGHT LLB SERVICE FITTING (SG x SG PIPE)		DWG NUMBER E2612SGP			
									REV	ECR	DESCRIPTION	DATE	BY	CHKR	PER EST NO: DXXXX EST FIN WT = 0.0000 lbs

DWG NUMBER
E2612SGP
JJ-MRKING

TITLE TO AND OWNERSHIP OF THIS ENGINEERING DATA REMAINS IN Mueller Co. NO USE IS TO BE MADE OF THIS DATA EXCEPT AS SPECIFICALLY AUTHORIZED BY Mueller Co. ASSENT ON THE PART OF THE RECIPIENT TO THESE CONDITIONS IS PRESUMED