

No.	QTY	DESCRIPTION	MATERIAL
1	1	SPUD	CAST LOW LEAD BRASS ALLOY
2	1	COMP GSKT	NITRILE ASTM D2000
3	1	WASHER	POLYPROPYLENE
4	1	CPLG NUT	CAST BRASS ASTM B62 ALLOY C83600

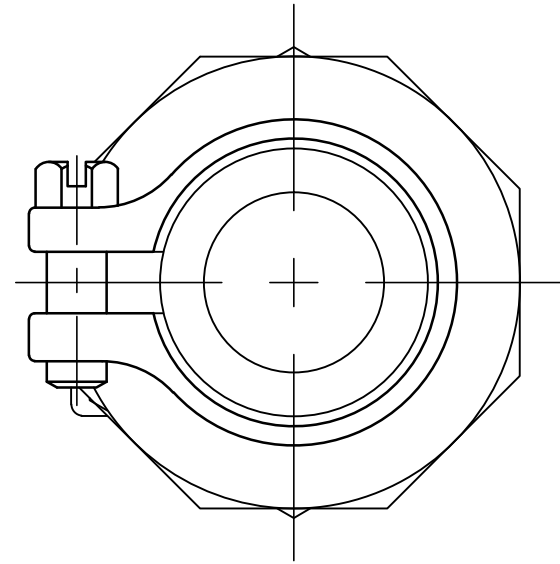
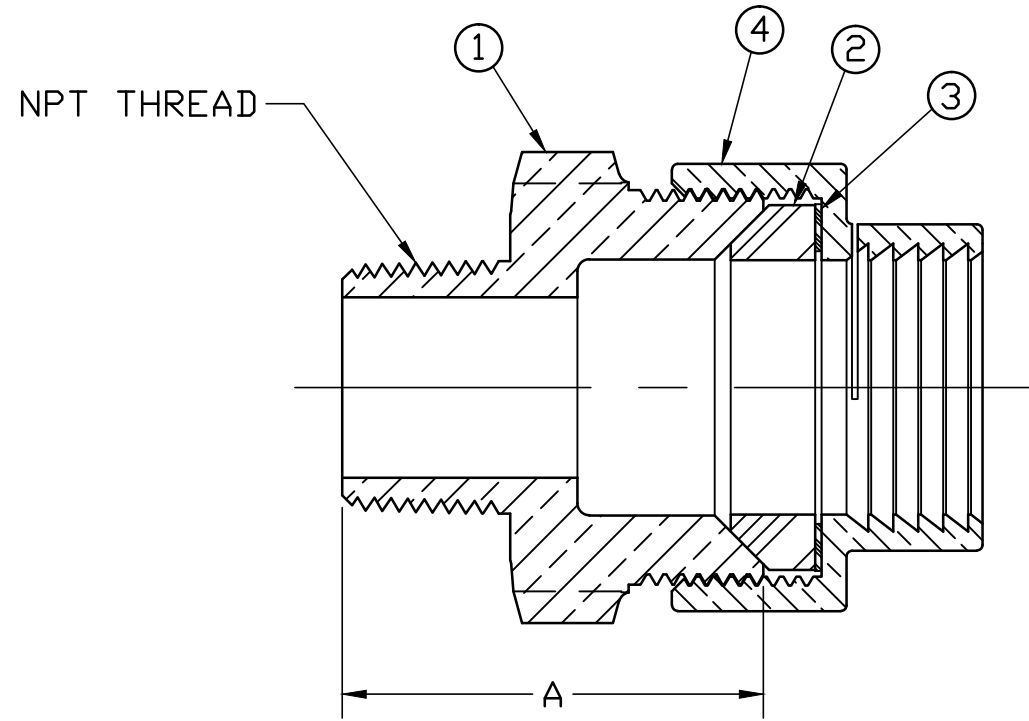

SIZE	A
1"	2.19
1" x 3/4"	2.14
1 1/2"	2.78
2"	2.95

ALL WETTED PARTS ARE LOW LEAD BRASS ALLOY

FILEPATH: PROD-ENG\JAMES JONES\SUBMITTALS\E2640

DRFTR	JGarvir	11/3/09	JONES		
CHKR					
ENGR					
MGR					
			UNLESS OTHERWISE NOTED	THIRD ANGLE PROJECTION	
			SURFACE PREPARATION:		
			BREAK CORNER(S) ---- .000		
			SURFACE FINISH -- XX RMS	REF. No.	
			TOLERANCE(S):	SCALE	
			LINEAR ----- ± .000		
			ANGULAR ----- ± 0°00'		
			STK No:		
			MAT'L:		
			DESCR.		
			LLB STRAIGHT SERVICE FITTING	DWG NUMBER	
			(MIP x IPS PVC PJ CTS)	E2640	
REV	ECR	DESCRIPTION	DATE	BY	CHKR

DWG NUMBER
E2640
JJ-MRKTG

TITLE TO AND OWNERSHIP OF THIS ENGINEERING DATA REMAINS IN Mueller Co. NO USE IS TO BE MADE OF THIS DATA EXCEPT AS SPECIFICALLY AUTHORIZED BY Mueller Co. ASSENT ON THE PART OF THE RECIPIENT TO THESE CONDITIONS IS PRESUMED