

No.	DESCRIPTION	MATERIAL
1	KEY CAP	CAST BRASS ASTM B62 ALLOY C83600
2	PIN	BRASS ASTM B16 ALLOY C36000
3	SPRING WASHER	PHOS BRONZE
4	O-RING	EPDM ASTM D2000
5	KEY	CAST LOW LEAD BRASS ALLOY
6	BODY	CAST LOW LEAD BRASS ALLOY
7	LOCK NUT	CAST BRASS ASTM B62 ALLOY C83600
8	RUBBER GASKET	NITRILE ASTM D2000
9	GASKET	ASTM D2000 (SBR)&410 STAINLESS STL
10	CONN NUT	CAST BRASS ASTM B62 ALLOY C83600

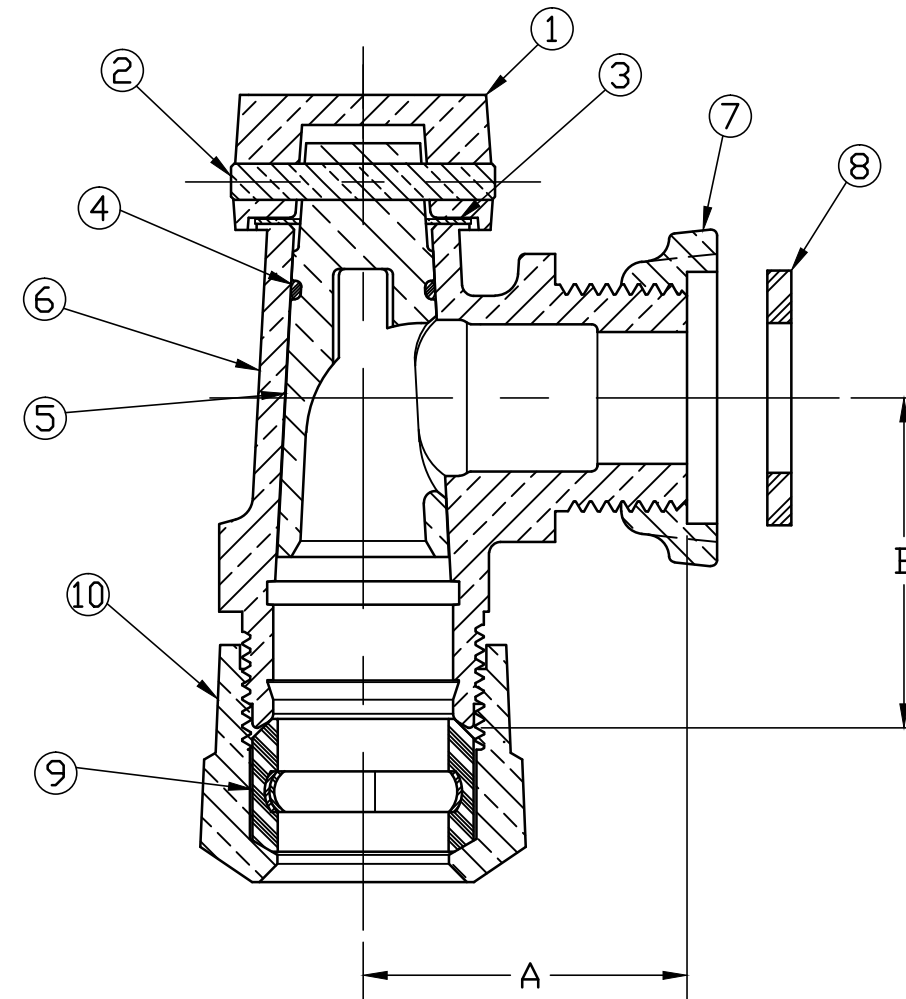

METER CONNX SIZE	A	B
5/8" x 3/4" x 3/4"	1.69	1.72

ALL WETTED PARTS ARE LOW LEAD BRASS ALLOY

FILEPATH: PROD-ENG\JAMESJONES\ASYSUBMITTALS\E6417WSG

DWG NUMBER
E6417WSG
442-MRKTG

TITLE TO AND OWNERSHIP OF THIS ENGINEERING DATA REMAINS IN Mueller Co. NO USE IS TO BE MADE OF THIS DATA EXCEPT AS SPECIFICALLY AUTHORIZED BY Mueller Co. ASSENT ON THE PART OF THE RECIPIENT TO THESE CONDITIONS IS PRESUMED

						DRFTR	RWB	5/13/16	JONES			
						CHKR					UNLESS OTHERWISE NOTED	THIRD ANGLE PROJECTION
						ENGR					SURFACE PREPARATION:	
						MGR					BREAK CORNER(S) ----- .000	
									SURFACE FINISH -- XX RMS	REF. No.	SCALE	
									TOLERANCE(S):		FULL	
									LINEAR ----- ± .000			
									ANGULAR ----- ± 0°00'			
									STK No:			
									MAT'L:			
									DESCR.	ANGLE METER STOP - LLB	DWG NUMBER	
										110CTS x IRON BAR	E6417WSG	
									PER EST NO: DXXXX	EST FIN WT = 0.0000 lbs		