

ITEM	DESCRIPTION	REQ'D	MATERIAL	A.S.T.M.		PART NUMBERS
1	HYDRANT BODY	1	DUCTILE IRON	A536	65-45-12	SEE CHART
2	NOZZLE INSERT - 2-1/2"	1	BRASS	B584	C89833	34-0113
* 3	NOZZLE INSERT - 4" / 4-1/2"	1	BRASS	B584	C89833	34-0115
4	O-RING	4	RUBBER	D2000	NITRILE	194572
5	O-RING	2	RUBBER	D2000	NITRILE	15-0192
6	HOSE NOZZLE O-RING	1	RUBBER	D2000	NITRILE	15-0242
7	PUMPER NOZZLE O-RING	1	RUBBER	D2000	BUNA N	15-0243
8	STEM - SHORT	1	BRASS	B584	C87600	26-0089
9	STEM - MEDIUM	1	BRASS	B584	C87600	26-0091
10	INSERT SHORT LENGTH	1	BRASS	B584	C89833	34-0688
11	INSERT MEDIUM LENGTH	1	BRASS	B584	C89833	34-0689
12	ASSY - HOLDER AND DISC 2-1/2"	1	BRASS	B584	C89833	27-0500
13	ASSY - HOLDER AND DISC 4" & 4-1/2"	1	BRASS	B584	C89833/C89836	27-0501
14	LOCKNUT - STEM	2	BRASS	B584	C89833	16-0016
15	NUT - OPERATING	2	BRASS	B584	C87600	21-0154
16	NUT - STEM	2	BRASS	B584	C83600	16-0254
17	SET SCREW	2	STAINLESS STEEL		S30200/S30300	20-0026
18	GASKET 2-1/2"	1	RUBBER	D2000	NEOPRENE	290272
* 19	GASKET 4" / 4-1/2"	1	RUBBER	D2000	NEOPRENE	15-0043
20	CAP - 2-1/2"	1	CAST IRON	A126		23-0168
* 21	CAP - 4" / 4-1/2"	1	CAST IRON	A126		23-0184
22	DOME CAP	1	DUCTILE IRON	B584	65-45-12	23-0166
23	DOME CAP O-RING	1	RUBBER	D2000	NITRILE	15-0276
24	S-HOOK	1	STEEL		ZINC CHROMATE PLATED	30-0021
25	CHAIN	1	STEEL		ZINC CHROMATE PLATED	30-0003

4" NOZZLE CONFIGURATION PART NUMBERS SHOWN FOR REFERENCE.
SEE CAT. RECORD FOR RESPECTIVE PARTS OR SUB. ASSEMBLIES
* 5" STORZ IS AVAILABLE FOR 250 PSI MODEL (4048)

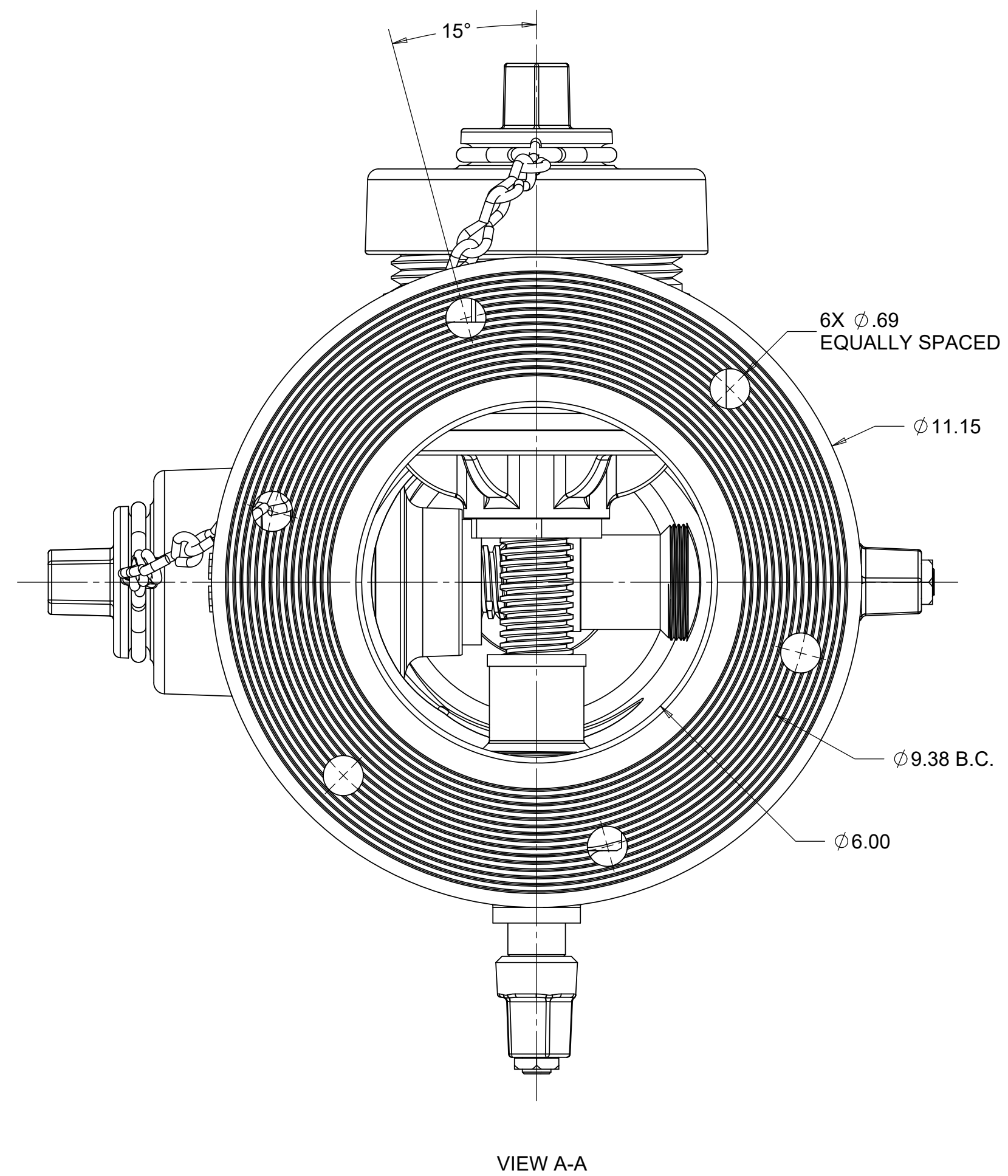

HYDRANT DESCRIPTION		
PART#	NOZZLE CONFIGURATION	FLANGE PATTERN
J4048AR	4-1/2" X 2-1/2"	6 - 0.75" HOLES, 9.38" DBC
J4048BR	4" X 2-1/2"	8 - 0.88" HOLES, 9.5" DBC
J4048CR	4" X 2-1/2"	6 - 0.88" HOLES, 9.5" DBC
J4048DR	4" X 2-1/2"	6 - 0.75" HOLES, 9.38" DBC
J4048ER	4-1/2" X 2-1/2"	8 - 0.88" HOLES, 9.5" DBC

CHART 1		
PART NUMBER	WORKING PRESSURE	MODEL NUMBER
34-0254	250 PSI	4048
34-0271	350 PSI	4048HP

NOTE:
1. THIS IS A REFERENCE DIMENSION ONLY. ACTUAL DIMENSIONS MAY VARY WITH TIGHTNESS OF VALVE AND CAP.

DWG. No. FH-575

B	ADDED DRILL PATTERN CHART	EO4327	MRG	9/12/18
A	ADD CHART FOR HP MODEL		JBC/CJD/CJD	6/17/15
REV.	DESCRIPTION	REF.	BY	DATE

SUBMITTAL DRAWING:
INTENDED FOR INFORMATIONAL
PURPOSES ONLY.

UNITS - (MILLIMETER) DECIMALS		TOLERANCES - MACHINING UNLESS OTHERWISE NOTED		THIRD ANGLE PROJECTION	
DRYER	JBC	4/17/15	MACH. .006/.016	125°	1:2
CHGR	CJD	4/17/15			
APP	CJD	4/17/15			
FRACTIONS		2 PL ±.025	3 PL ±.010	REF. NO. 12	
F.O. NUMBER		SEE TABLE		STR. NO.	
JAMES JONES COMPANY		JAMES JONES COMPANY		B FH-575	
		J4048 - WITH IRON CAPS		SHEET 1 OF 1	